

Sinusgenerator

DL6GL 10.02.2018, adapted from Elektor July/August 1983

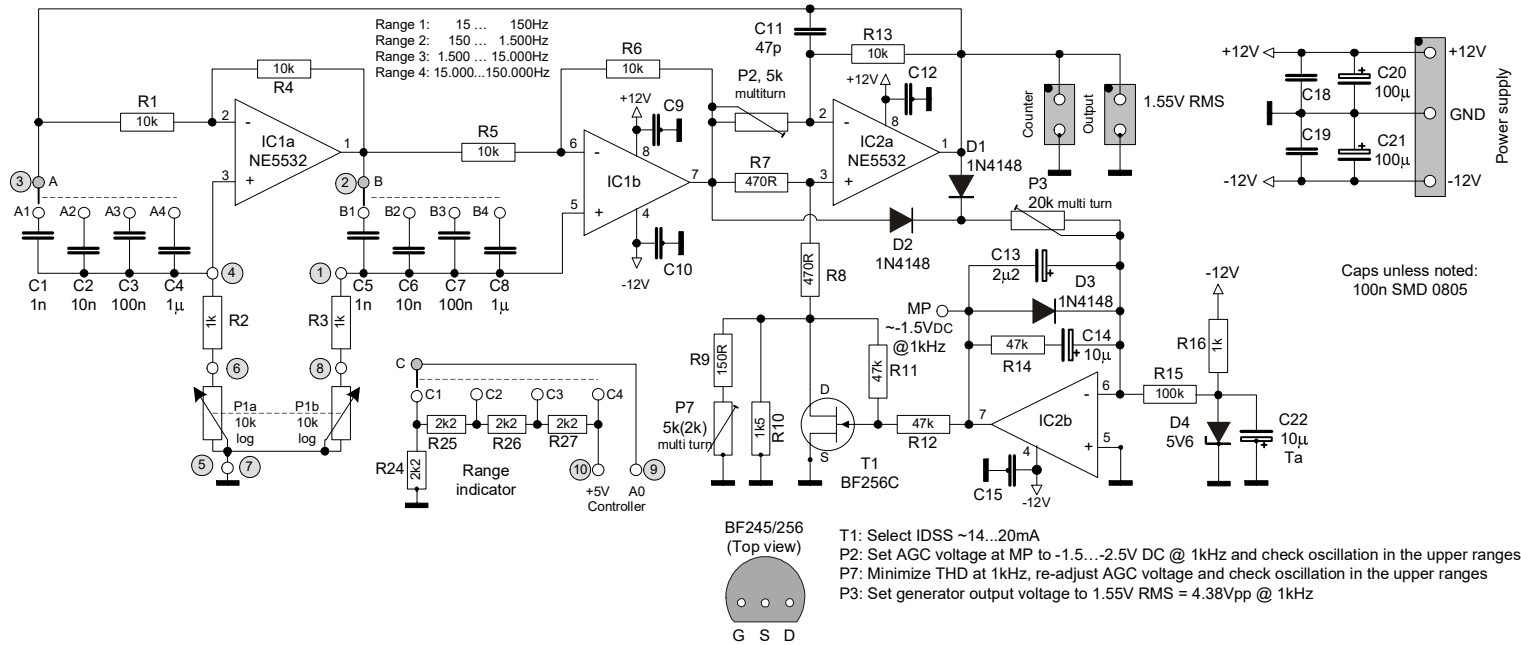

Sinusgenerator Output amplifier

DL6GL 10.02.2018

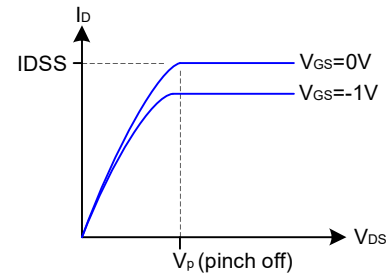
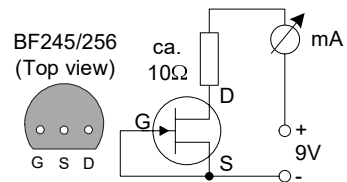
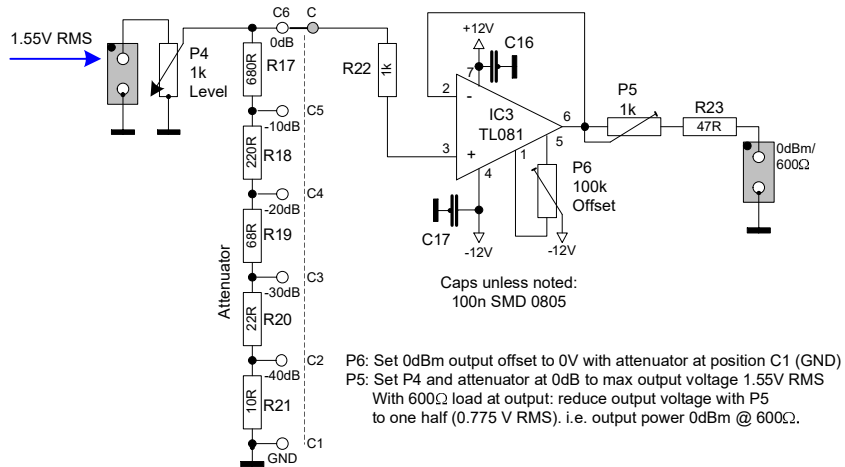

Sinusgenerator Power supply

DL6GL 19.11.2017

